



Careers  
Festival  
2026

OWN  
YOUR  
READY

 **RMIT**  
UNIVERSITY

Careers, Alumni &  
Industry Relations

CAREERS FESTIVAL 2026

**INDUSTRY**

**GUIDELINE**

**OWN  
YOUR**

**READY**

Get Career Ready Your Way

<b>1</b>	<b>About RMIT Vietnam</b>	<b>1</b>
<b>2</b>	<b>About Careers Festival 2026</b>	<b>3</b>
<b>3</b>	<b>Key message of the Careers Festival 2026</b>	<b>3</b>
<b>4</b>	<b>Careers Fair Details</b>	<b>4</b>
<b>5</b>	<b>Booth Set Up</b>	<b>8</b>
<b>6</b>	<b>Sustainability Guideline</b>	<b>10</b>
	<b>General Site Rules</b>	<b>11</b>
	<b>Contact Points</b>	<b>12</b>

**OWN YOUR  
READY**



RMIT University Vietnam has a world-class reputation for excellence in higher education, offering quality, industry-responsive programs.



### **A world-class Australia education**

Students enrolled at RMIT University Vietnam graduate with a degree awarded by RMIT University in Melbourne



### **Top 150 of world's universities**

RMIT ranks in the top 150 global universities in the 2024 QS World University Rankings



### **Excellent graduate outcomes**

77.9% in full-time employment within 3-4 months after graduation  
Data from Graduate Outcomes Survey (GOS)  
for the past 5 years

## Hanoi Campus

- Number of active students: approximately 2000 students
- Programs being offered in Hanoi
  - Business
  - Economics and Finance
  - Human Resource Management
  - Global Business
  - Management
  - Logistics and Supply Chain Management
  - Digital Business
  - Digital Marketing
  - Tourism & Hospitality Management
  - Design Studies
  - Professional Communication
  - Psychology
  - Information Technology
  - Software Engineering



**OWN YOUR  
READY**

The **RMIT Careers Festival** is our flagship annual career event by the Careers, Alumni & Industry Relations team, designed to equip students with the skills, insights, and connections to thrive in today's evolving world of work.

In 2026, the theme "Own Your Ready" focuses on practical readiness, understanding industry expectations while building the skills, mindset, and confidence to succeed in real professional environments.

Highlights include:

- **Build career confidence:** Learn how to navigate today's job market, understand industry expectations, and take practical steps toward goals.
- **Explore employability opportunities:** Connect directly with companies and discover various career pathways.
- **Stand out as career-ready talent:** Showcase your strengths to employers who are actively looking for well-prepared candidates.
- **Expand the professional network:** Engage with leading organizations and build connections that support your long-term career journey.





Careers Festival 2026 is built on the belief that career readiness is not a fixed destination, but a journey students can actively shape. The concept empowers students to take ownership of their future by recognising that “being ready” is something they can define, build, and grow over time. Through meaningful experiences and real-world insights, the festival encourages students to develop readiness in a way that aligns with their individual aspirations and strengths.

“Own Your Ready” captures this mindset by inviting students to take ownership of their preparation and progress. Every student’s journey looks different, shaped by individual goals, timelines, and strengths.

Together, Careers Festival 2026 communicates both empowerment and flexibility, positioning the university as a supportive partner that provides guidance, opportunities, and real-world exposure while allowing students to define what readiness truly means for students.

**Organizers**  
 Careers, Alumni & Industry Relations

**CAREERS FESTIVAL 2026**

**OWN YOUR READY**

**Get Career Ready Your Way**

**REGISTER HERE**

<b>APRIL 20</b>	<b>INDUSTRY GATEWAY #1</b> Pathways to Professional Careers with Deloitte	<b>MAY 12</b>	<b>★ CAREERS FAIR DAY</b>
<b>MAY 05</b>	<b>INDUSTRY GATEWAY #2</b> From Campus to Corporate with [...]	<b>JULY 02</b>	Asia Intelligence Leadership Challenge

# 4

## CAREERS FAIR DETAILS

### Preparation Timeline



DATE	ACTIONS	PIC
Fri 27 Mar	Confirm participation in RMIT Careers Fair 2026	RMIT
Fri 27 Mar - Tue 13 May	Share JDs of your open positions with RMIT students	Company
Mon 20 Apr - Tue 28 Apr	<ul style="list-style-type: none"> <li>• Read Events Guideline</li> <li>• Complete <a href="#">registration form</a> for company representatives &amp; booth equipment/materials for the Careers Fair day</li> </ul>	Company
Wed 6 May	Confirm the list of allowed booth equipment	RMIT
Mon 11 May	Venue open for site check and equipment drop-off Location: RMIT Innovation Hub, 3PM - 5PM	RMIT & Company
Tue 12 May	<b>Careers Fair Day</b> <ul style="list-style-type: none"> <li>• Arrival time: 9AM</li> <li>• Moving out time: 1:30 - 2:00 PM</li> </ul>	RMIT & Company

**Date**

Tuesday 12 May 2026

**Time**

10:00 AM - 2:00 PM

**Venue**

RMIT Innovation Hub (1.1B.004), Lobby - Tower B, RMIT Hanoi Campus,  
521 Kim Ma, Ba Dinh, Hanoi

**Agenda**

TIME	SESSION
9:00 AM - 9:30 AM	Company booth setup
9:30 AM - 10:00 AM	Networking Event (Industry Partners with RMIT Lecturers & Staffs)
10:00 AM - 10:15 AM	Opening Ceremony
10:00 AM - 1:15 PM	Careers Fair Activities
1:15 PM - 1:30 PM	Closing Ceremony
1:30 PM - 2:00 PM	Tear-down & departure



**LAYOUT - CAREER FAIR 2026**

**12th May, 2026**

**Innovation Hub (1.1B.004)**

**ANNOTATIONS**

	Student Square Table x37		Stand-by-me screen (Job Shop) x1
	Chair x69		

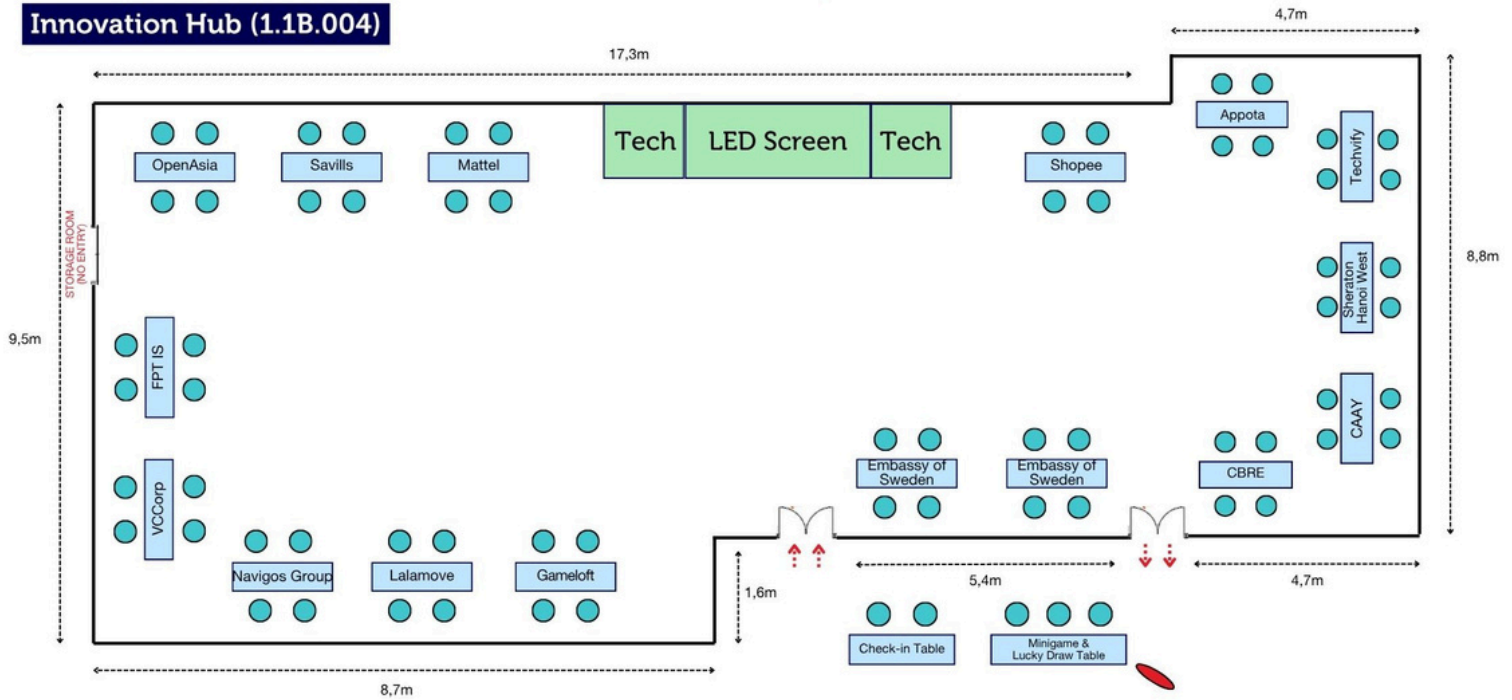

**Notes:**

- There are coffee shops inside campus.
- There is a wellbeing room inside campus. Please contact the nearest event volunteers and organisers for emergency cases.
- Smoking is prohibited on campus.
- Ensure that your company representatives attend the full duration of the Careers Fair (9 AM - 2 PM).
- At least 2 staff members should be present at your booth to engage with students and answer questions.
- If this is your first time participating in an RMIT Careers Fair, we encourage you contact us directly for further support.



**Communication support**



RMIT Careers Festival landing page



RMIT Career Ready Hub Facebook

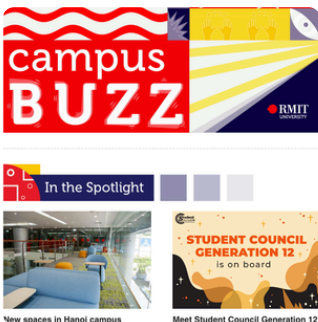
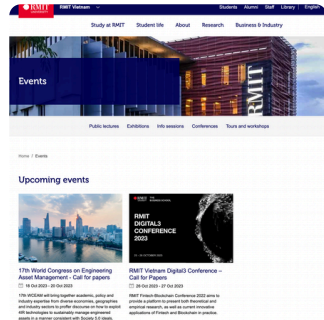
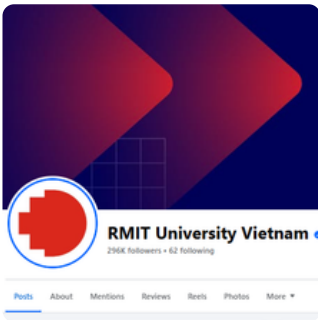

RMIT internal communication channels



RMIT promotion booth & other POSM

**Networking tea**



There are available slots for the networking breakfast

**Coffee shop available in campus**

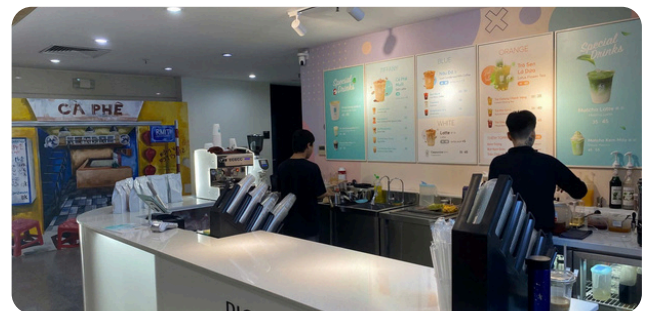

Bring your own water bottle to refill. Please avoid single-use bottles.

**Volunteer support**

01 student volunteer will be assigned to support 02 company booths

**Booth amenities:**

- 01 standard booth & backdrop with company's name on top
- 01 table (0.8mW x 1.2mL x 0.7mH)
- 02 chairs
- 01 black tablecloth
- 01 electricity socket (please bring additional electric sockets if needed)

**Lunch voucher**

Lunch will be served during  
12:00 - 12:30 PM

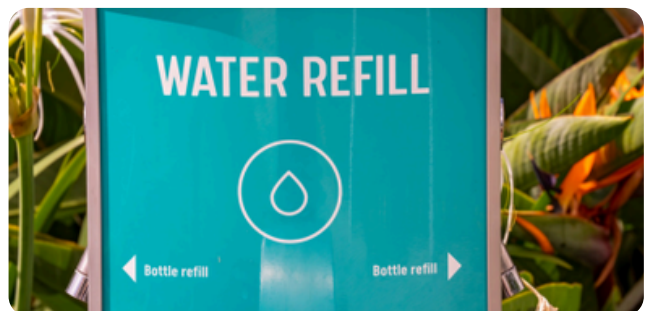
**Water Refill stations inside venue**

Bring your own water bottle to refill.  
Please avoid single-use bottles.



**Knowledge with Action – RMIT’s Strategy to 2031**

In a world of diminishing resources, RMIT aims to be a leader in sustainability. This commitment extends beyond providing sustainability education and research; it includes leading by example in University operations

As part of the Event Guideline, the following Sustainable Guideline applies to participating companies, students, and staff to create successful Careers Festival 2026 that foster a strong sense of community, while also minimizing negative impacts on the environment.

Your support by following our Sustainable Guidelines will play a crucial role in lasting this culture among the young and soon-to-be practitioners!

**Do**



01 standee



Laptops, iPads



Digitalize promotion materials



Distribute sustainable merchandise

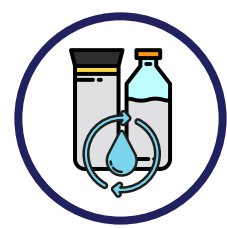

Bring your own bottle and refill at our provided water stations.

**Don't**



No paper flyers



No speaker



No TV



No merchandise with single-used packaging



No additional installation

### Photo Usage Policy

- Event photos must not be used for commercial purposes.
- Please refrain from bringing large filming crews, as this may disrupt the event and limit space for participants.
- To respect the privacy of attendees, please avoid taking close-up shots of individuals.

### Registration Form

Register company representatives, booth equipment and materials bringing to Career Fair in the Registration Form.

Deadline to complete: 4pm, Tuesday 28 April 2026



Do not exceed the speed limit. Follow the instructions from security officers to ensure the safety in the campus' transporting.



Keep the campus' environment clean. No litter or make the environment polluted.



No food consumption, wine, beer, and other alcohol allowed in the area of Career Fair.



Immediately report accident, incident, near-miss or hazard when noticed.



No participation in unsafe act, behave in unsafe manner or present a hazard or risk that might harm yourself or others.



Please take care of your own belongings.



If you are unwell or having flu-like symptoms, please stay at home.



Maintain good personal hygiene: wash hands, use hand sanitizers.

## CAREERS, ALUMNI & INDUSTRY RELATIONS DEPT.

- **Ms. Loan Le – Career Development & Internship Consultant**  
Email: [le.loan@rmit.edu.vn](mailto:le.loan@rmit.edu.vn)  
Phone: +84 243 201 2621
- **Ms. Trang Phung - Internship & Employment Consultant**  
Email: [thiquynhtrang.phung@rmit.edu.vn](mailto:thiquynhtrang.phung@rmit.edu.vn)  
Phone: +84 243 201 2531



Careers  
Festival  
2026

OWN  
YOUR  
READY

 **RMIT**  
UNIVERSITY

Careers, Alumni &  
Industry Relations

**CAREERS FESTIVAL 2026**

**THANK YOU**

**OWN  
YOUR  
READY**

Get Career Ready Your Way